

TOP-FLOOR

Submersible DRAINAGE pumps

 Clear water

 Domestic use



PERFORMANCE RANGE

- Flow rate up to **160 l/min** (9.6 m³/h)
- Head up to **9 m**

APPLICATION LIMITS

- **3 m** maximum immersion depth (with a sufficiently long power cable)
- Maximum liquid temperature **+40 °C** (Maximum liquid temperature +90 °C for a maximum of 3 minutes intermittent service)
- Passage of suspended solids up to **Ø 2 mm**
- Suction down to **2 mm** above ground level
- Continuous service **S1**

CONSTRUCTION AND SAFETY STANDARDS

The pumps are complete with a **5 m** power cable

EN 60335-1
IEC 60335-1
CEI 61-150

EN 60034-1
IEC 60034-1
CEI 2-3



CERTIFICATIONS

Company with management system certified DNV
ISO 9001: QUALITY

INSTALLATION AND USE

The **TOP-FLOOR** series is suitable for use with **clear water** that does not contain abrasive particles.

Because of their ability to drain water to a level of 2 millimetres above ground level, they are suitable for use in domestic emergencies where a small area must be drained to the lowest possible level.

PATENTS - TRADE MARKS - MODELS

- Registered EU Design n. 342159-0011

OPTIONS AVAILABLE ON REQUEST

- Pumps with float switch
- Special mechanical seal
- Pumps with a **10 m** long power cable.
 - ➔ N.B.: Standard EN 60335-2-41 states that the power cable must be 10 m long for outdoor applications
- Other voltages

GUARANTEE

2 years subject to terms and conditions

CHARACTERISTIC CURVES AND PERFORMANCE DATA

60 Hz n= 3450 min⁻¹

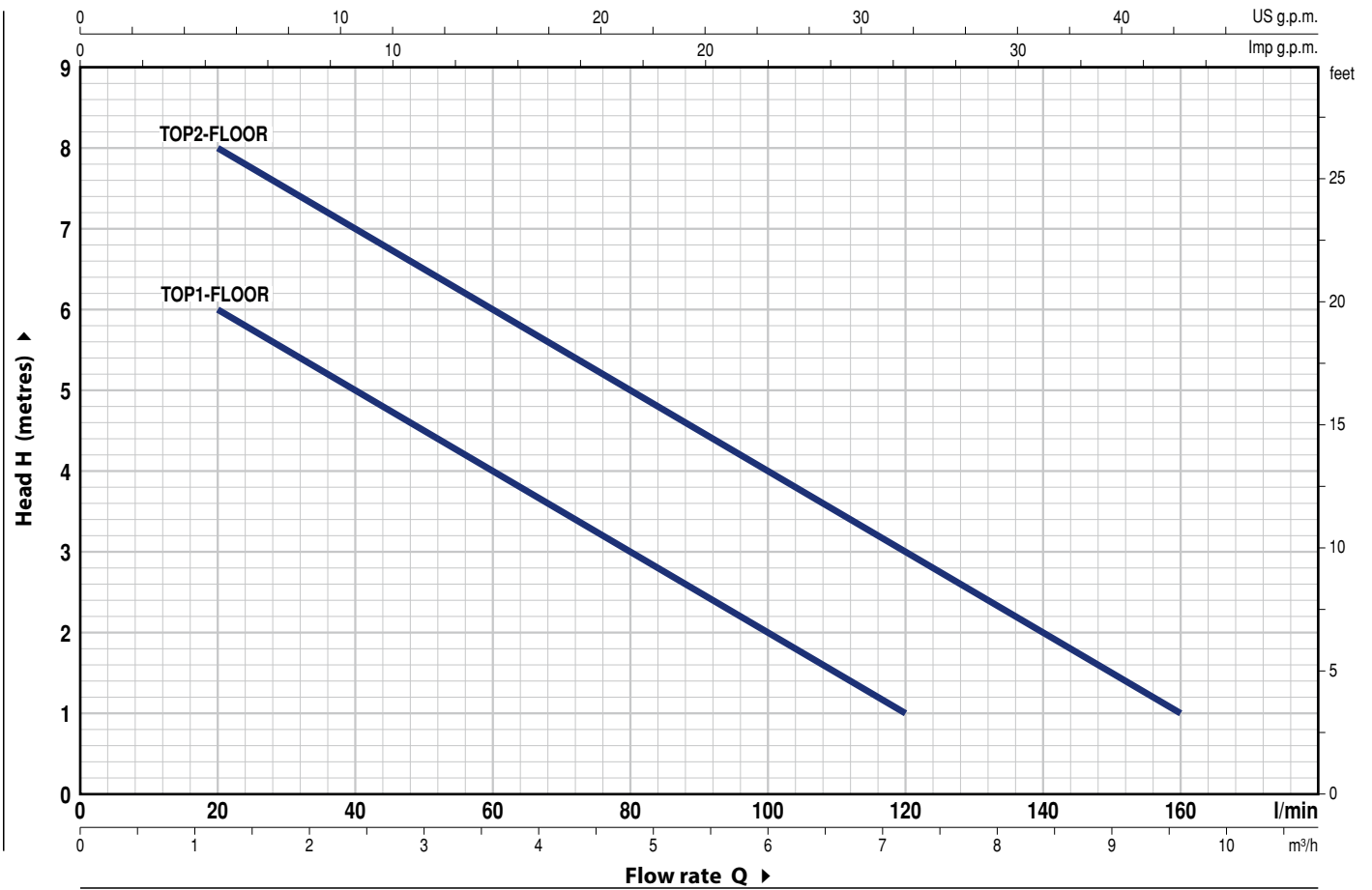

MODEL	POWER (P ₂)		Q	0	1.2	2.4	3.6	4.8	6.0	7.2	8.4	9.6
	kW	HP		0	20	40	60	80	100	120	140	160
Single-phase												
TOP 1-FLOOR	0.25	0.33	H metres	7	6	5	4	3	2	1		
TOP 2-FLOOR	0.37	0.50		9	8	7	6	5	4	3	2	1

Q = Flow rate H = Total manometric head

Tolerance of characteristic curves in compliance with EN ISO 9906 Grade 3B.

TOP-FLOOR

POS. COMPONENT CONSTRUCTION CHARACTERISTICS

1	PUMP BODY	Technopolymer
2	SUCTION FILTER	Technopolymer
3	SUCTION PLATE	Stainless steel AISI 304 (AISI 316L for LA versions)
4	DIFFUSER	Technopolymer
5	IMPELLER	Noryl
6	MOTOR CASING	Stainless steel AISI 304 (AISI 316L for LA versions)
7	MOTOR CASING PLATE	Stainless steel AISI 304
8	MOTOR SHAFT	Stainless steel AISI 431 (AISI 316L for LA versions)

9 SHAFT WITH DOUBLE SEAL AND OIL CHAMBER

<i>Seal Model</i>	<i>Shaft Diameter</i>	<i>Materials</i>		
		<i>Stationary ring</i>	<i>Rotational ring</i>	<i>Elastomer</i>
STA-12R	Ø 12 mm	Ceramic	Graphite	NBR

10	LIP SEAL	Ø 12 x Ø 19 x H 5 mm
----	-----------------	----------------------

11	BEARINGS	6201 ZZ / 6201 ZZ
----	-----------------	-------------------

12 CAPACITOR

<i>Pump Single-phase</i>	<i>Capacitance</i>	
	<i>(220 V)</i>	<i>(110 V or 127 V)</i>
TOP 1-FLOOR	10 µF - 450 VL	16 µF - 250 VL
TOP 2-FLOOR	10 µF - 450 VL	16 µF - 250 VL

13 ELECTRIC MOTOR

TOP-FLOOR: single-phase 220 V - 60 Hz with thermal overload protector incorporated into the winding.
 – Insulation: class F
 – Protection: IP X8

14 HANDLE ASSEMBLY (resin sealed)

Complete with 5 metres long "H07 RN-F" **power cable** with Schuko plug

15 HOSE CONNECTOR WITH RING NUT

Ø 25 mm hose connection for TOP1 - FLOOR
 Ø 35 mm hose connection for TOP2 - FLOOR

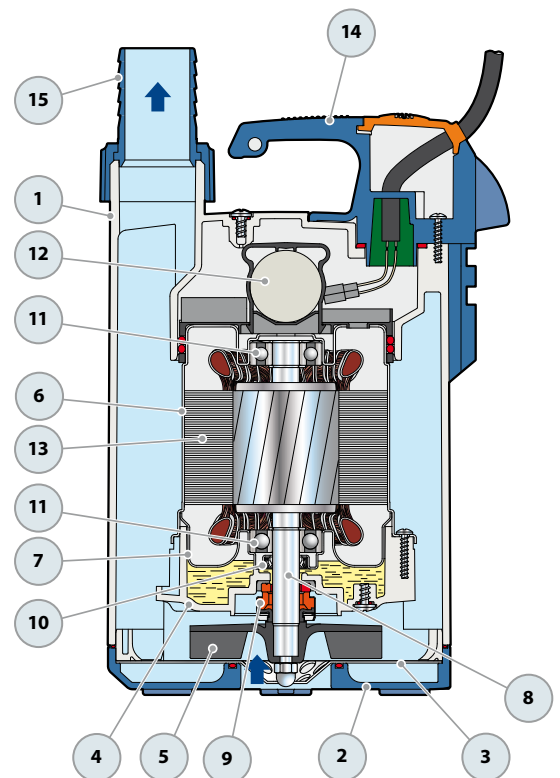

DIMENSIONS AND WEIGHT

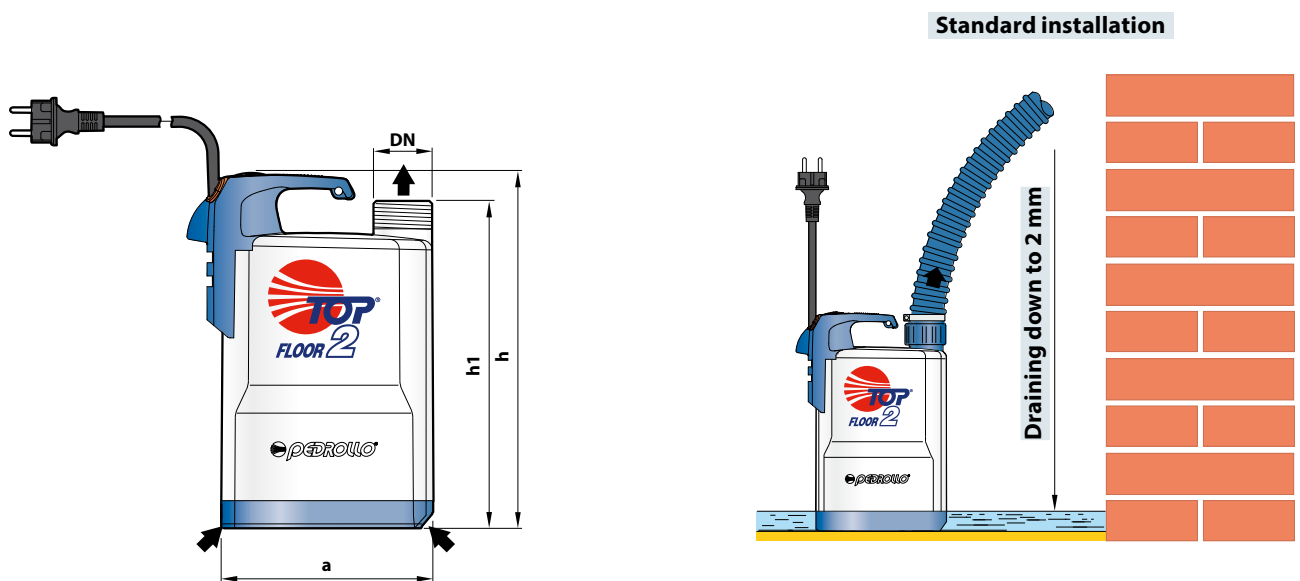

MODEL	PORT	DIMENSIONS mm			Minimum drying level	kg
		DN	a	h		
Single-phase						
TOP 1-FLOOR	1¼"	152	257	237	2 mm	5.1
TOP 2-FLOOR						5.2

ABSORPTION

MODEL	VOLTAGE		
	220 V	110 V	127 V
Single-phase			
TOP 1-FLOOR	1.5 A	3.0 A	2.6 A
TOP 2-FLOOR	2.5 A	5.0 A	4.3 A

PALLETIZATION

MODEL	GROUPAGE	CONTAINER
Single-phase	n. pumps	n. pumps
TOP 1-FLOOR	96	144
TOP 2-FLOOR	96	144