

2÷4CP

Multi-stage centrifugal pumps



PERFORMANCE RANGE

- Flow rate up to **130 l/min** (7.8 m³/h)
- Head up to **52 m**

APPLICATION LIMITS

- Manometric suction lift up to **7 m**
- Liquid temperature between **-10 °C** and **+40 °C**
- Ambient temperature up to **+40 °C**
- Max. working pressure **6 bar**
- Continuous service **S1**

CONSTRUCTION AND SAFETY STANDARDS

EN 60335-1
IEC 60335-1
CEI 61-150

EN 60034-1
IEC 60034-1
CEI 2-3



CERTIFICATIONS

COMPANY WITH MANAGEMENT SYSTEM
CERTIFIED BY DNV
ISO 9001: QUALITY
ISO 14001: ENVIRONMENT AND SAFETY



A130



ПРМОТЕКТ-168

INSTALLATION AND USE

Suitable for use with clean water and liquids that are not chemically aggressive towards the materials from which the pump is made. As a result of their quietness, these pumps are widely used in domestic applications such as the distribution of water in combination with small and medium sized pressure sets, and for the irrigation of gardens and allotments, etc. The pump should be installed in an enclosed environment, or at least sheltered from inclement weather.

PATENTS - TRADE MARKS - MODELS

- Registered Community Design n° 002073635

OPTIONALS AVAILABLE ON REQUEST

- Other voltages or 60 Hz frequency

GUARANTEE

2 years subject to terms and conditions

CHARACTERISTIC CURVES AND PERFORMANCE DATA

50 Hz n= 2900 1/min HS= 0 m

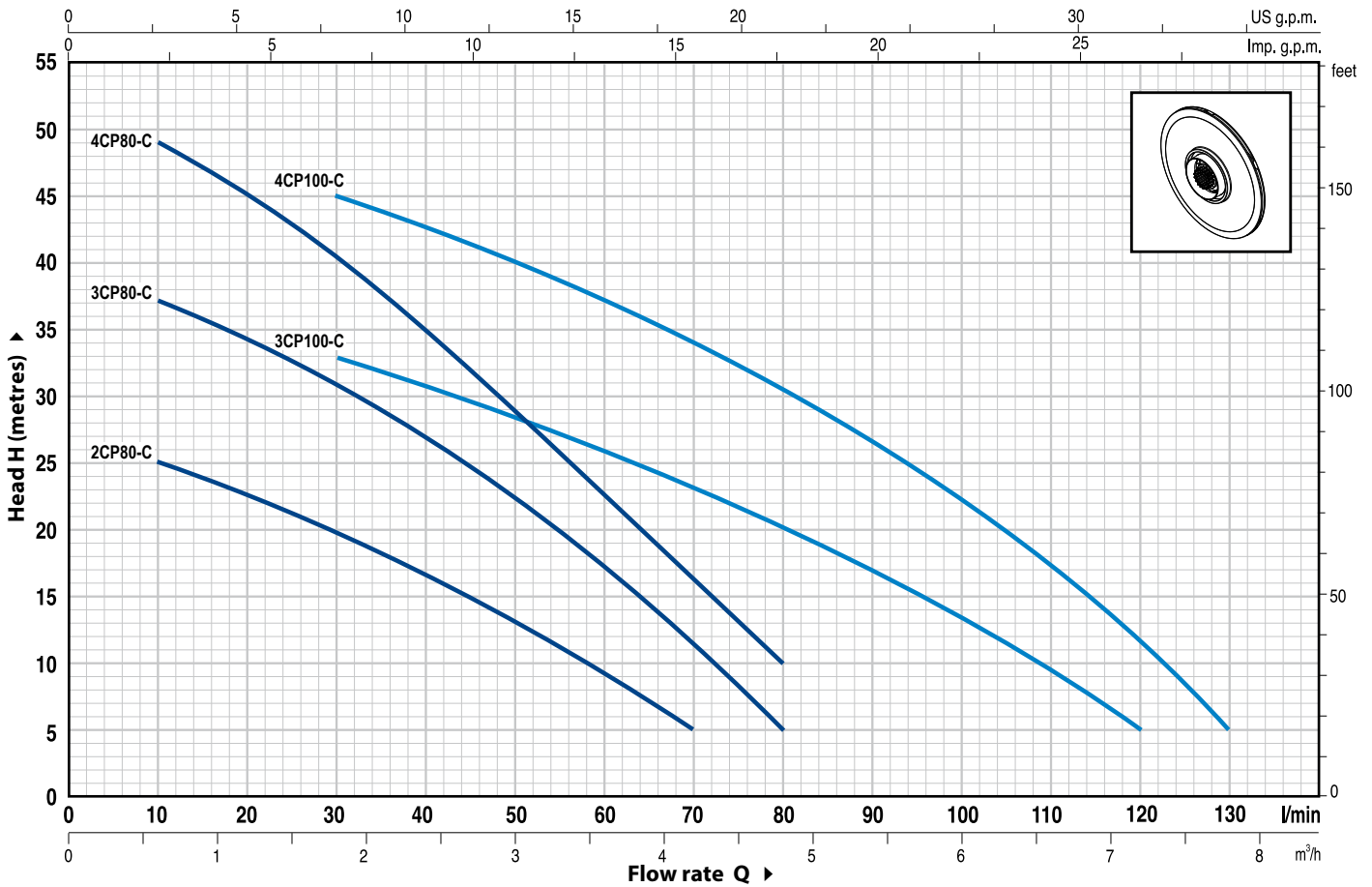

MODEL		POWER		Q	m ³ /h																		
Single-phase	Three-phase	kW	HP		0	0.3	0.6	0.9	1.2	1.5	1.8	2.4	3.0	3.6	4.2	4.8	5.4	6.0	6.6	7.2	7.8		
				l/min	0	5	10	15	20	25	30	40	50	60	70	80	90	100	110	120	130		
2CPm 80-C	-	0.37	0.50	H metres	27	26	25	24	22.5	21	20	16.5	13	9	5								
3CPm 80-C	3CP 80-C	0.45	0.60		40	38	37	36	34.5	33	31	27	22.5	17	11	5							
4CPm 80-C	4CP 80-C	0.60	0.85		52	50	49	47	44.5	42	40	34	28.5	22.5	16	10							
3CPm 100-C	3CP 100-C	0.60	0.85		38	37	36	35	34.5	33.5	33	31	28	26	23	20	17	13.5	10	5			
4CPm 100-C	4CP 100-C	0.75	1		50	50	49	48	47	46	45	42	39.5	37	34	30.5	26.5	22	17	11	5		

Q = Flow rate H = Total manometric head HS = Suction height

Tolerance of characteristic curves in compliance with EN ISO 9906 Grade 3.

POS.	COMPONENT	CONSTRUCTION CHARACTERISTICS				
1	PUMP BODY	Cast iron, complete with threaded ports in compliance with ISO 228/1				
2	BODY BACKPLATE	Stainless steel AISI 304				
3	IMPELLERS	Noryl				
4	DIFFUSERS	Noryl complete with anti-wear ring				
5	MOTOR SHAFT	Stainless steel EN 10088-3 - 1.4104				
6	MECHANICAL SEAL	<i>Seal</i>	<i>Shaft</i>	<i>Materials</i>		
		<i>Model</i>	<i>Diameter</i>	<i>Stationary ring</i>	<i>Rotational ring</i>	<i>Elastomer</i>
		STA-13	Ø 13 mm	Ceramic	Graphite	NBR
7	BEARINGS	<i>Pump</i>	<i>Model</i>			
		2CP 80-C	6202 ZZ - C3 / 6201 ZZ			
		3CP 80-C				
		4CP 80-C				
		3CP 100-C	6203 ZZ / 6203 ZZ			
4CP 100-C						
8	CAPACITOR	<i>Pump</i>	<i>Capacitance</i>			
		<i>Single-phase</i>	<i>(230 V or 240 V)</i>	<i>(110 V)</i>		
		2CPm 80-C	10 µF 450 VL	25 µF 250 VL		
		3CPm 80-C	12.5 µF 450 VL	25 µF 250 VL		
		4CPm 80-C	14 µF 450 VL	25 µF 250 VL		
		3CPm 100-C	20 µF 450 VL	60 µF 300 VL		

- 9 ELECTRIC MOTOR 2-3-4CPm: single-phase 230 V - 50 Hz with thermal overload protector built-in to the winding.
 2-3-4CP: three-phase 230/400 V - 50 Hz.
- ➔ Pumps fitted with the three-phase motor option offer IE2 (IEC 60034-30) class high performance
- Insulation: F class.
 - Protection: IP X4.

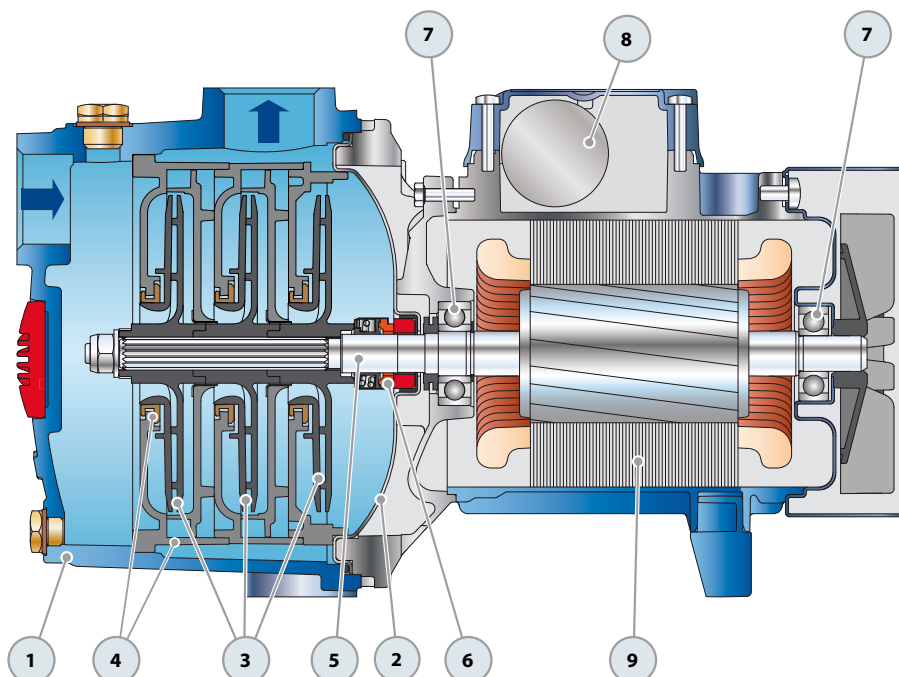

DIMENSIONS AND WEIGHT

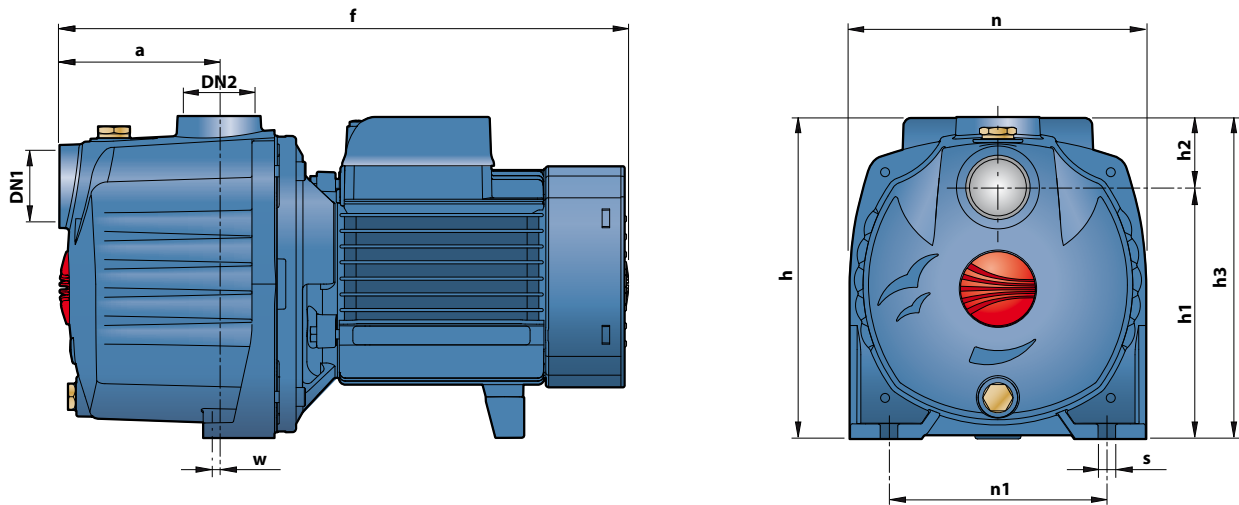

MODEL		PORTS		DIMENSIONS mm										kg	
Single-phase	Three-phase	DN1	DN2	a	f	h	h1	h2	h3	n	n1	w	s	1~	3~
2CPm 80-C	-	1"	1"	85	303	172	134	38	172	158	116	1.5	9	9.0	-
3CPm 80-C	3CP 80-C			110	328									9.8	9.3
4CPm 80-C	4CP 80-C			85	303	10.4								9.9	
3CPm 100-C	3CP 100-C			110	356	191								13.7	12.7

ABSORPTION

MODEL	VOLTAGE (single-phase)		
	230 V	240 V	110 V
2CPm 80-C	2.4 A	2.4 A	4.8 A
3CPm 80-C	3.4 A	3.3 A	6.8 A
4CPm 80-C	4.3 A	4.2 A	8.6 A
3CPm 100-C	4.1 A	4.0 A	8.2 A
4CPm 100-C	6.0 A	5.8 A	12.0 A

MODEL	VOLTAGE (three-phase)					
	230 V	400 V	690 V	240 V	415 V	720 V
3CP 80-C	2.5 A	1.4 A	0.8 A	2.4 A	1.4 A	0.8 A
4CP 80-C	3.4 A	2.0 A	1.1 A	3.3 A	1.9 A	1.1 A
3CP 100-C	3.1 A	1.8 A	1.0 A	3.0 A	1.7 A	1.0 A
4CP 100-C	4.5 A	2.6 A	1.5 A	4.3 A	2.5 A	1.4 A

PALLETIZATION

MODEL		GROUPAGE				CONTAINER			
Single-phase	Three-phase	n° pumps	H (mm)	kg		n° pumps	H (mm)	kg	
				1~	3~			1~	3~
2CPm 80-C	-	98	1547	867	-	140	2150	1228	-
3CPm 80-C	3CP 80-C	98	1547	945	896	140	2150	1340	1270
4CPm 80-C	4CP 80-C	98	1547	1082	1053	140	2150	1536	1494
3CPm 100-C	3CP 100-C	98	1547	994	965	140	2150	1410	1368
4CPm 100-C	4CP 100-C	84	1661	1150	1150	108	2102	1471	1471

